

3-Phase EMI FILTER

Feature and Benefits

- Compact
- Superior Performance
- Chassis mounting 3 Phase Filter

Typical Application

- Three-phase variable speed motor drives, servo drives, inverters and converters
- Applications comprising energy conversion devices like machines or process automation equipment
- HVAC equipment, elevators, power supplies, UPS and further three-phase applications



Typical circuit Diagram

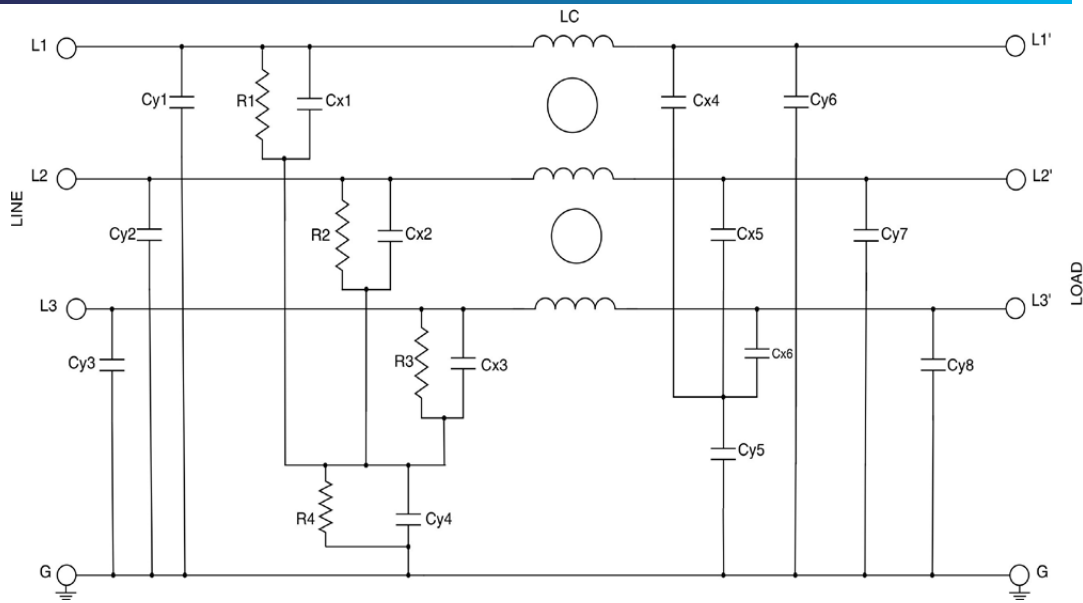

Technical Specifications:

Maximum Continuous Operating Voltage	: 440/520VAC
Operating Frequency	: 50/60 Hz
Current ratings	: 3A to 200A @ 40°C
High Potential test voltage	: L to G 3000Vdc for 1 Minute L to L 1100Vdc for 1 Minute
Overload Capability	: 135% of Rated current for 15 minutes
Temperature range	: -25°C to +85°C
Climatic Category	: 25/85/21

FILTER SELECTION TABLE

Model Number	Leakage current (mA)	Rated Current @40°C	Termination	Weight (Kg)
BL423-3-T	8.5	3A	4	0.6
BL423-6-T	8.5	6A	4	0.7
BL423-8-T	8.5	8A	4	2
BL423-10-T	8.5	10A	4	2
BL423-16-T	8.5	16A	4	3
BL423-20-T	8.5	20A	4	3
BL423-25-T	8.5	25A	4	3
BL423-36-T	8.5	36A	10	3
BL423-50-T	8.5	50A	10	3
BL423-60-T	12	60A	16	8
BL423-75-T	12	75A	16	8
BL423-80-T	12	80A*	25	8
BL423-100-T	12	100A*	25	8
BL423-125-T	12	125A*	M10	9
BL423-150-T	12	150A*	M10	9
BL423-160-T	12	160A	M10	9
BL423-200-T	12	200A	M10	9

MECHANICAL DETAILS

7 Amp Terminal block (10mm²)

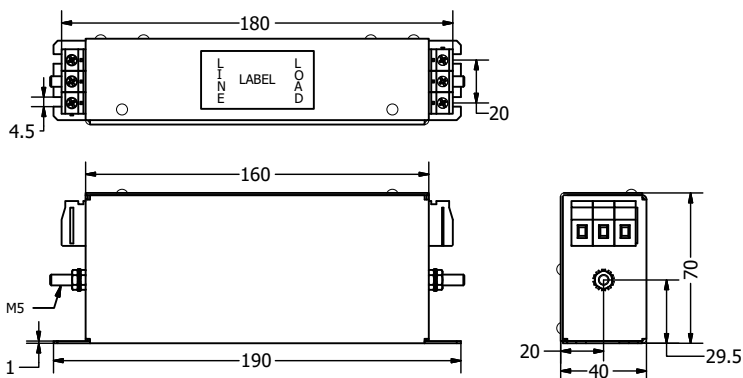

16 Amp Terminal block (10mm²)

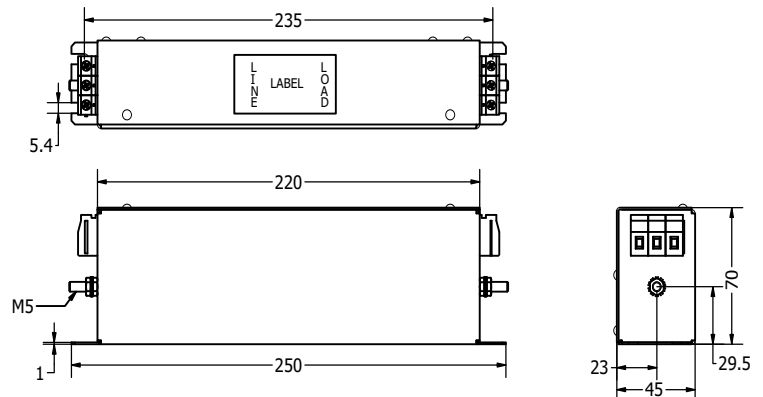

MECHANICAL DETAILS

30 Amp Terminal block (10mm²)

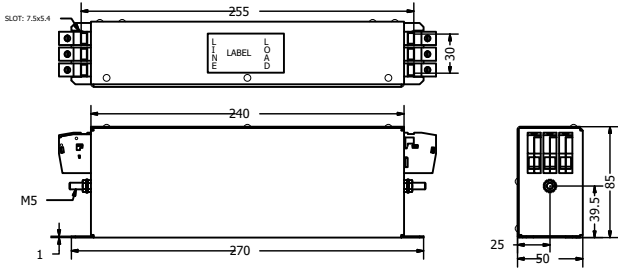

42 Amp Terminal block (10mm²)

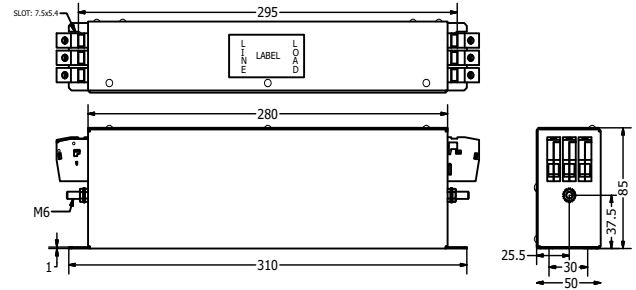

55 Amp Terminal block (25mm²)

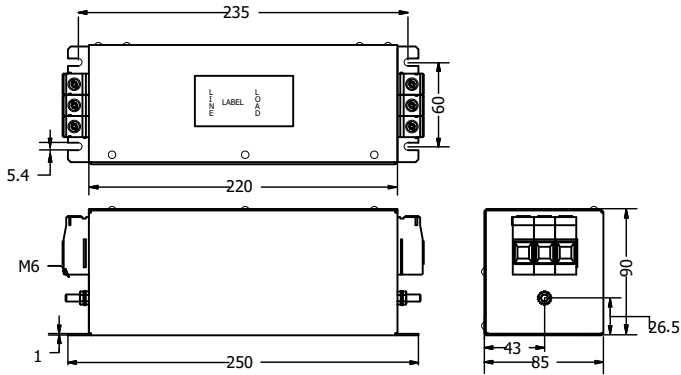

75 Amp Terminal block (25mm²)

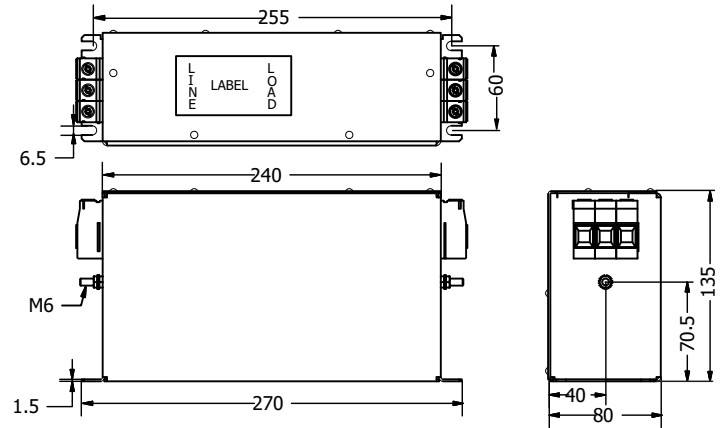

100 & 130Amp Terminal block (50mm²)

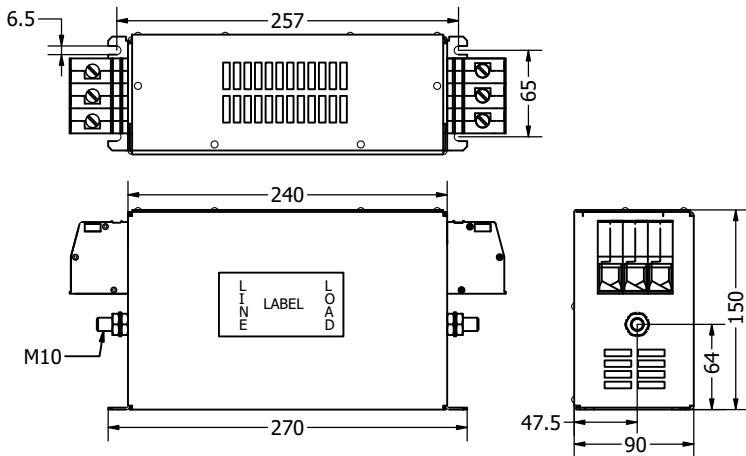

200Amp Terminal block (95mm²)

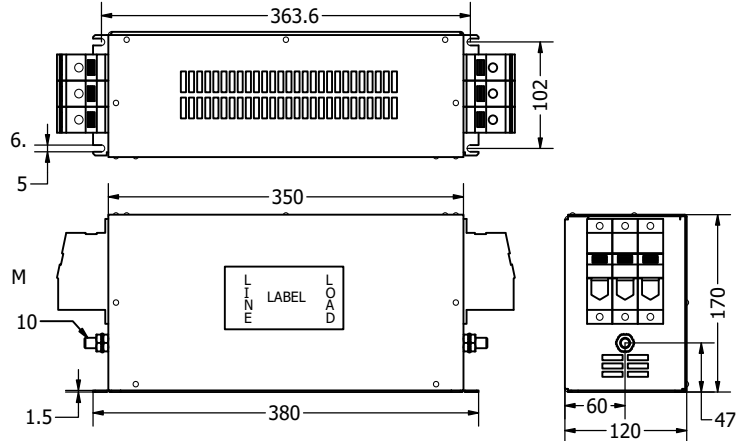

**All Dimension are in mm

CONNECTION DETAILS

	4	10	16	25
Wire Section (mm ²)	4mm ²	10mm ²	16mm ²	25mm ²

TYPICAL INSERTION LOSS, dB (50/50 Ohm)

Insertion Loss: Common mode - —
Differential mode- —

7 A type

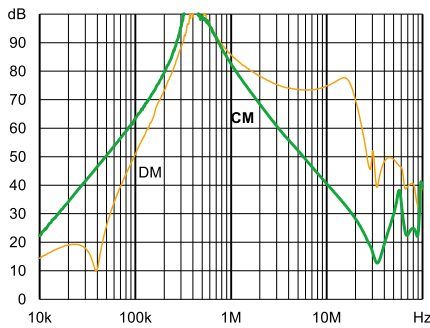

16 A type

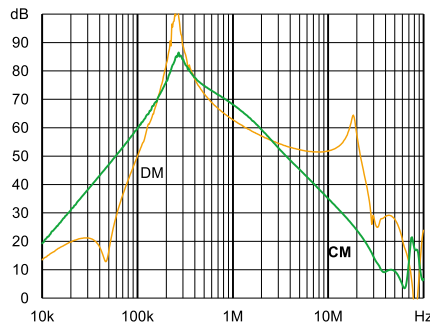

30 A type

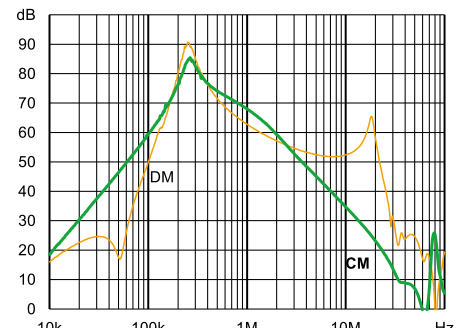

42 A type

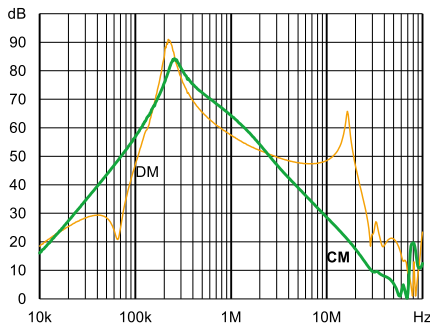

55 A type

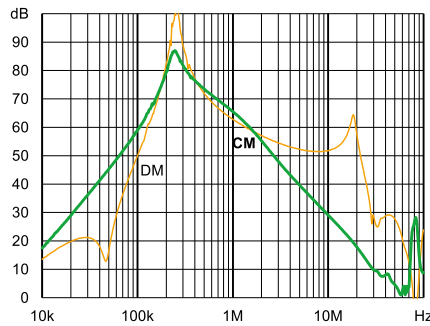

75 A type

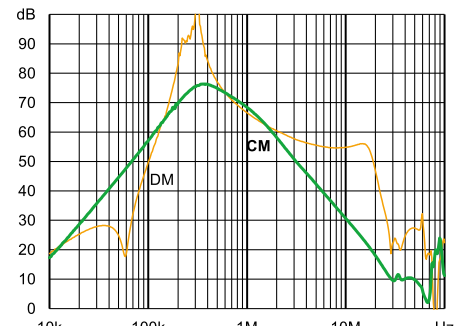

100 A type

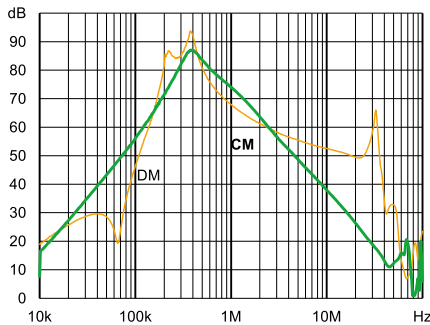

130 A type

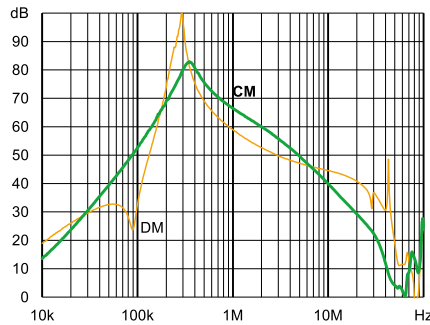

200A type

